

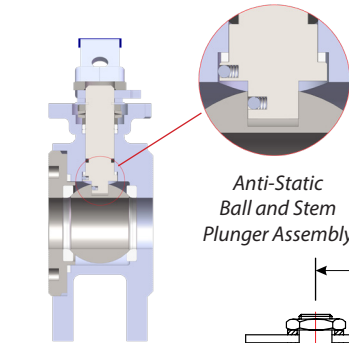

V205 Series Wafer (Monoblock) Flanged Ball Valves

V205 Series ball valves feature a compact design, occupying minimal space in the process line. Unlike conventional ball valves, they have no body-connection joints, eliminating the risk of leakage between the body and the end cap. In addition to manual lever operation, V205 Series valves offer excellent process control with direct ISO 5211 mounting flanges compatible with pneumatic, electric, and hydraulic actuators. V205 valves are manufactured in PN16, PN40, PN64, and PN100 pressure classes.

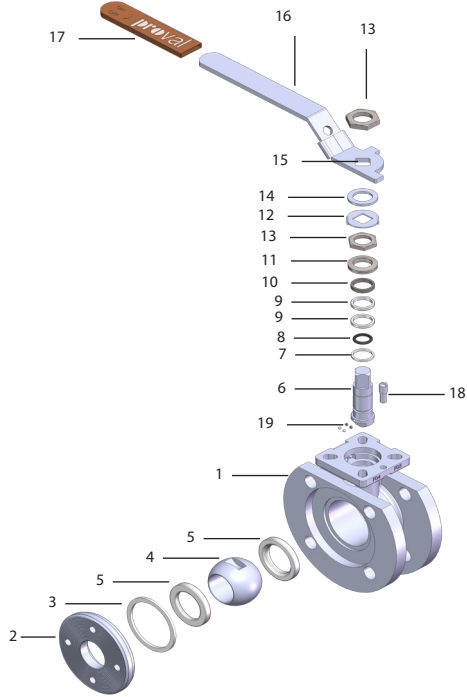

Anti-Static Ball and Stem Plunger Assembly

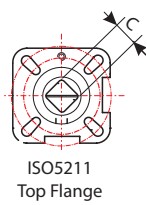

ISO5211 Top Flange

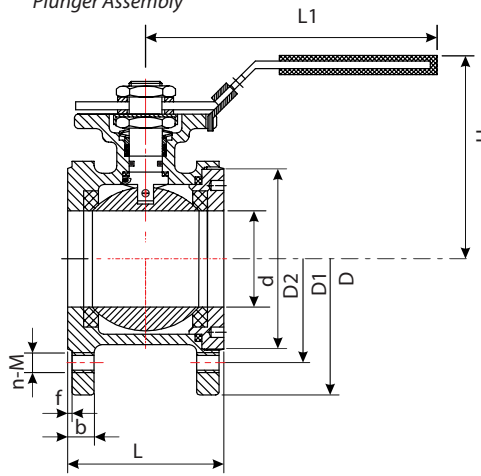

AISI316 Monoblock Ball Valve



Pneumatic Actuated Monoblock Ball Valve

Material List

No	Part Name	Material (AISI316)	Material (A216WCB)	Qty	No	Part Name	Material (AISI316)	Material (A216WCB)	Qty	No	Part Name	Material (AISI316)	Material (A216WCB)	Qty
1	Body	AISI316	WCB	1	8	Stem Seal	Viton	Viton	1	15	Locking Plate	AISI304	AISI304	1
2	Insert	AISI316	WCB	1	9	Packing	PTFE	PTFE	1	16	Handle	AISI304	AISI304	1
3	Body Seal	PTFE	PTFE	1	10	Gland	AISI304	AISI304	1	17	Handle Sleeve	Plastic	Plastic	1
4	Ball	AISI316	AISI316	1	11	Belleville Washer	AISI301	AISI301	2	18	Stop Pin	AISI304	AISI304	1
5	Ball Seat	Glass Fiber Reinforced PTFE Graphite Reinforced PTFE		2	12	Locking Washer	AISI304	AISI304	1	19	Anti-Static Device	AISI316	AISI316	2
6	Stem	AISI316	AISI316	1	13	Gland Nut	AISI304	AISI304	2					
7	Thrust Washer	PTFE	PTFE	1	14	Washer	AISI304	AISI304	2					

Dimensions(mm)

Size (DN)	d	L	D	PN16		PN40		#150		b	f	H	L1	C	ISO5211 Top Flange	Torque (N.m)	Kv (m ³ /h)	Weight (Kg)
				D1	n-M	D1	n-M	D1	n-M									
15	15	36	95	65	4-M12	65	4-M12	60,3	4-1/2"UNC	12	2	70	115	9	F03	5	35	1,11
20	20	38	105	75	4-M12	75	4-M12	69,8	4-1/2"UNC	12	2	78	115	9	F03	8	46	1,48
25	25	50	115	85	4-M12	85	4-M12	79,4	4-1/2"UNC	12	2	90	160	11	F04/F05	10	72	1,95
32	32	53	140	100	4-M16	100	4-M16	88,9	4-1/2"UNC	14	2	100	160	11	F04/F05	14	105	3,10
40	40	65	150	110	4-M16	110	4-M16	98,4	4-1/2"UNC	15	3	105	200	14	F05/F07	18	170	4,18
50	50	78	165	125	4-M16	125	4-M16	120,6	4-5/8"UNC	16	3	125	200	14	F05/F07	25	275	5,37
65	65	98	185	145	4-M16	145	8-M16	139,7	4-5/8"UNC	16	3	140	155	17	F07/F10	48	507	8,18
80	76	118	200	160	8-M16	160	8-M16	152,4	4-5/8"UNC	18	3	145	255	17	F07/F10	75	905	11,92
100	94	140	220	180	8-M16	190	8-M20	190,5	8-5/8"UNC	18	3	175	300	17	F07/F10	110	1414	16,92
125	125	195	250	210	8-M16	220	8-M24	215,9	8-3/4"UNC	22	3	228	300	22	F10/F12	200	2520	27,5
150	150	225	285	240	8-M20	250	8-M24	241,3	8-3/4"UNC	22	3	246	300	22	F10/F12	300	3950	36,5
200	200	275	340	295	12-M20	320	12-M27	298,4	8-3/4"UNC	24	3	310	400	27	F12/F14	400	5705	68



Lever Op. Flanged Ball Valve with Limit Switch Box



PN100 Monoblock Ball Valve